



Construction

Close-coupled centrifugal pumps; electric motor with extended shaft directly connected to the pump.
Pump casing with axial suction and radial delivery on top, main dimensions and performance according to EN 733.

Connections: Flanges according to PN 10, EN 1092-2.

Counter-flanges (on request)

Sizes	Flanges
from NM 32/... to NM 50/...	Screwed flanges EN 1092-1, PN 16
from NM 65/... to NM 100/250	Flanges for welding EN 1092-1, PN 10

Applications

- For clean liquids without abrasives, which are non-aggressive for the pump materials (solids content up to 0.2%).
- For water supply.
- For heating, air conditioning, cooling and circulation plants.
- For civil and industrial applications.
- For fire fighting applications. - For irrigation.

Operating conditions

Liquid temperature from -10 °C to +90 °C.
Ambient temperature up to 40° C.
Total suction lift up to 7 m.
Maximum permissible working pressure up to 10 bar.
Continuous duty.

Motor

2-pole induction motor, 50 Hz (n = 2900 rpm).
NM: three-phase 230/400 V ± 10% up to 3 kW;
400/690 V ± 10% from 4 to 75 kW.
Insulation class F.
Protection IP 54.
Constructed in accordance with IEC 60034.

Special features on request

- Other voltages. - Frequency 60 Hz (as per 60 Hz data sheet).
- Protection IP 55.- Special mechanical seal.
- Packed gland (only for NM standard construction).
- Single-phase motor (NMM) up to 1.5 kW.
- Explosion proof construction in accordance with Directive 94/9 EEC (ATEX).
- Higher or lower liquid or ambient temperatures.

Materials

Components	NM	B-NM
Pump casing	Cast iron	Bronze
Lantern bracket	GJL 200 EN 1561	G-Cu Sn 10 EN 1982
Impeller	Cast iron	Bronze
	GJL 200 EN 1561	G-Cu Sn 10 EN 1982
	Brass P- Cu Zn 40 Pb 2 UNI 5705 for NM 32/12-16-20, NM 40/20 B-NM 32/125-160-200, B-NM 40/200	
Shaft	Cr Ni steel AISI 303 up to 2.2 kW	Cr Ni Mo steel AISI 316
	Cr steel AISI 430 from 3 kW to 75 kW	
Mechanical seal	Carbon - Ceramic - NBR	
Counter-flanges	Steel Fe 430B UNI 7070	

Coverage chart n ≈ 2900 rpm

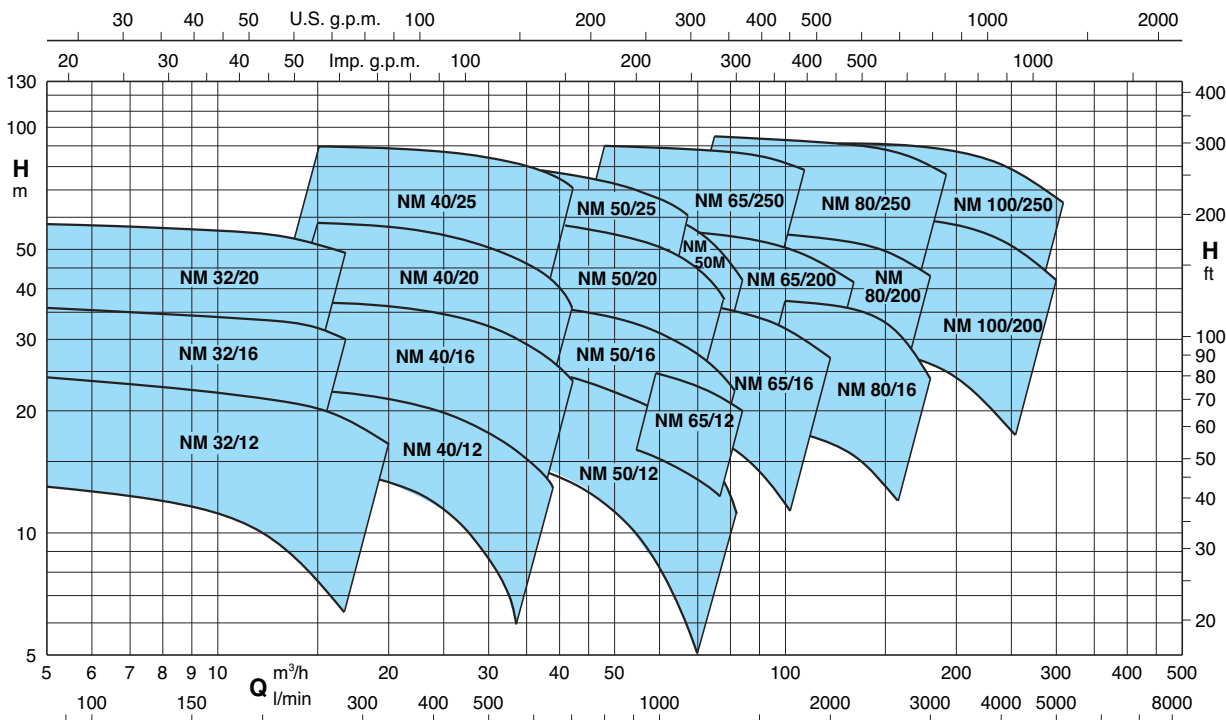

Performance n ≈ 2900 rpm

B-NM	NM	P ₂		Q m ³ /h l/min	6,6	7,5	8,4	9,6	10,8	12	13,2	15	16,8	18,9	21	24	27	30
		kW	HP		110	125	140	160	180	200	220	250	280	315	350	400	450	500
					H _m													
B-NM 32/125FE	NM 32/12FE	0,55	0,75		12,5	12,5	12	11,5	11	10	9	7,5						
B-NM 32/125DE	NM 32/12DE	0,75	1		18	18	17,5	17	16,5	16	15,5	14						
B-NM 32/125AE	NM 32/12AE	1,1	1,5		23	23	22,5	22	21,5	21	20,5	19						
B-NM 32/125SE	NM 32/12SE	1,5	2		23,5	23,5	23	22,5	22	21,5	21	20,5	19*	18,5*	16,5*	13*		
B-NM 32/160BE	NM 32/16BE	1,5	2		29,5	29,5	29	28,5	27,5	27	26	25*	22,5*					
B-NM 32/160AE	NM 32/16AE	2,2	3		35,5	35,5	35	34,5	34	33,5	33	32*	30*					
B-NM 32/200DE	NM 32/20DE	2,2	3		38	37,5	37	36	35	33,5	32							
B-NM 32/200CE	NM 32/20CE	3	4		45	44,5	44	43,5	42,5	41	40	38	36*					
B-NM 32/200AE	NM 32/20AE	4	5,5		57,5	57	56	55,5	55	54,5	53,5	51,5	49*					

B-NM	NM	P ₂		Q m ³ /h l/min	15	16,8	18,9	21	24	27	30	33	37,8	39	42	45	48	54
		kW	HP		250	280	315	350	400	450	500	550	630	650	700	850	800	900
					H _m													
B-NM 40/125F/A	NM 40/12F/A	1,1	1,5		14	13,5	13	12	11	9,5	8	6						
B-NM 40/125C/A	NM 40/12C/A	1,5	2		17,5	17	16,5	16	15	13,5	12	10,5	7,5	6,5				
B-NM 40/125A/A	NM 40/12A/A	2,2	3		22	22	21,5	21	20	19	18	16,5	14	13	11,5			
B-NM 40/160C/A	NM 40/16C/A	2,2	3		23	22,5	22	21,5	20	18,5	16,5	14,5	11	10				
B-NM 40/160B/A	NM 40/16B/A	3	4		29	28,8	28	27,5	26,5	25	23,5	21,5	18	17	14			
B-NM 40/160A/A	NM 40/16A/A	4	5,5		37	36,5	36,5	36	35	33,5	32	30,5	27	26	23,5	20	17	
B-NM 40/200DE	NM 40/20DE	4	5,5		39	38	37	35,5	33,5	30,5	27	22,5	14					
B-NM 40/200CE	NM 40/20CE	4	5,5		41,5	40,5	39,5	38	36	33,5								
B-NM 40/200BE	NM 40/20BE	5,5	7,5		50	49,5	48,5	47,5	45,5	43,5	41,5	37,5	30,5					
	NM 40/20ARE	5,5	7,5		55	54,5	54	53	51	49								
B-NM 40/200A/A	NM 40/20A/A	7,5	10		57,5	57	56,5	55,5	54,5	52,5	50,5	48	42,5	40,5	35			
B-NM 4025/C/A	NM 40/25C/A	9,2	12,5		61	61	60,5	59,5	58,5	56,5	53,5	49,5	41,5	40	33,5			
B-NM 4025/B/A	NM 40/25B/A	11	15		69,5	69,5	69	68,5	67	65,5	63,5	60,5	53,5	51	45			
B-NM 4025/A/A	NM 40/25A/A	15	20		90	90	89,5	89	88,5	87	85	83	77,5	76	70,5			

B-NM	NM	P ₂		Q m ³ /h l/min	24	27	30	33	37,8	42	48	54	60	66	69	72	75	78	81	84
		kW	HP		400	450	500	550	630	700	800	900	1000	1100	1150	1200	1250	1300	1350	1400
					H _m															
B-NM 50/125F/A	NM 50/12F/A	2,2	3				15,5	15	14	13,5	12	10	8	6						
B-NM 50/125D/A	NM 50/12D/A	3	4				20	19,5	18,5	18	16,5	14,5	13	10,5	9	8				
B-NM 50/125A/A	NM 50/12A/A	4	5,5				24	24	23	22,5	21	19,5	17,5	15	14	12,5	11,5	10		
B-NM 50/125S/A	NM 50/12S/A	4	5,5				26,5	26	25,5	24,5	23,5	22	20	18	16,5	15,5	14	13	11	
B-NM 50/160B/A	NM 50/16B/A	5,5	7,5				31	30,5	29,5	28	26	24	21,5	19	17,5	15,5	13,5	11,5	9,5	
B-NM 50/160A/A	NM 50/16A/A	7,5	10				38,5	38	37,5	36,5	34,5	32,5	30	27	25,5	24	22,5	20,5	19	
B-NM 50/200B/A	NM 50/20B/A	9,2	12,5		48	47,5	47,5	47	45,5	44,5	42,5	40	37	33	30,5	28	25,5	23		
B-NM 50/200A/A	NM 50/20A/A	11	15		55	55	54,5	54,5	53,5	52	50	48	45	41,5	39,5	37	35	32,5		
B-NM 50/200S/A	NM 50/20S/A	15	20		60	60	59,5	59,5	58,5	57,5	55,5	53,5	50,5	47	45	43	40,5	37		
B-NM 5025/C/A	NM 50/25C/A	11	15		55	54,5	54	53	51,5	49,5	46	41,5	35,5	28,5	24,5					
B-NM 5025/B/A	NM 50/25B/A	15	20		69	68,5	68	67,5	66	64	61	57	52,5	46,5	43					
B-NM 5025/A/A	NM 50/25A/A	18,5	25		80,5	80,5	80	79,5	78,5	77	74,5	71,5	67	61,5	58,5					
B-NM 5025/65EE	NM 50M/EE	11	15			48	47,5	47	46	45	43	40	37	32	29,5	27	24			
B-NM 5025/65DE	NM 50M/DE	15	20				57	56,5	56	55	53	51	48	44,5	42	39,5	37	32	29	25*
B-NM 5025/65CE	NM 50M/CE	18,5	25				68	67,5	67	66,5	65	63	61	58	56	53,5	51,5	48	45,5	42*

B-NM	NM	P ₂		Q m ³ /h l/min	37,8	42	48	54	60	66	75	84	96	108	120	132	150	168	
		kW	HP		630	700	800	900	1000	1100	1250	1400	1600	1800	2000	2200	2500	2800	
					H _m														
	NM 65/12EE	4	5,5		18	17,5	17	16,5	16	15	13,5*								
B-NM 65/125CE	NM 65/12CE	5,5	7,5		22	21,5	21	20,5	20	19,5	18	15,5*							
B-NM 65/125AE	NM 65/12AE	7,5	10		26	25,5	25	24,5	24	23,5	22	20*							
B-NM 65/160EE	NM 65/16EE	5,5	7,5				20	19,5	19	18,5	17	15,5	13*	10*					
B-NM 65/160DE	NM 65/16DE	7,5	10				26	25,5	25	24,5	23,5	22	20*	16,5*	13*				
B-NM 65/160CE	NM 65/16CE	9,2	12,5				30	29,5	29	28,5	28	26,5	24,5*	21,5*	18*				
B-NM 65/160BE	NM 65/16BE	11	15				33,5	33	32,5	32	31	30	28*	25,5*	22*				
B-NM 65/160AE	NM 65/16AE	15	20				38	37,5	37	36,5	36	35	33*	30,5*	27*				
B-NM 65/200CE	NM 65/20CE	15	20				44	43,5	43	42,5	41	39,5	37,5*	35*	31*	27*			
B-NM 65/200BE	NM 65/20BE	18,5	25				50	49,5	49	48,5	47,5	46,5	44,5*	42*	39*	35*			
B-NM 65/200AE	NM 65/200AE	22	30				56,5	56	55,5	55	54,5	53,5	51*	48,5*	45,5*	41,5*			
B-NM 65/250CE	NM 65/250CE	22	30				64	63,5	63	61,5*	60*	57,5*	54,5*	50*					
B-NM 65/250BE	NM 65/250BE	30	40				79,5	79	78,5	78*	77*	75*	72*	67*					
B-NM 65/250AE	NM 65/250AE	37	50				90	89,5	89	88,5*	87,5*	86*	83,5*	78,5*					

Performance n ≈ 2900 rpm

B-NM	NM	P ₂		Q m ³ /h l/min	H m																
		kW	HP		75	84	96	108	120	132	150	168	180	192	210	240	270	300			
B-NM 80/160EE	NM 80/16EE	7,5	10	20	19,3	18,5	17,5*	16,5*	15,5*	13*											
B-NM 80/160DE	NM 80/16DE	9,2	12,5	23	22,5	22	21*	19,5*	18*	15*											
B-NM 80/160CE	NM 80/16CE	11	15	27,5	27	26,5	25,5*	24,5*	23*	20*	16*										
B-NM 80/160BE	NM 80/16BE	15	20	34	33,5	33	32,5*	32*	31*	28*	23*	18*									
B-NM 80/160AE	NM 80/16AE	18,5	25	38,5	38	37,5	37*	36,5*	36*	33*	29*	24*									
	NM 80/200BE	22	30	46,5	46	45,5	44,5	43,5*	42*	39*	35,5*	32*									
	NM 80/200AE	30	40	56	55,5	55	54	53*	52*	49,5*	46*	43*									
	NM 80/250EE	22	30	51	50	48,5	46,5	44,5*	42*	38*	33*	29*									
	NM 80/250DE	30	40	65	64	62,5	61	59*	56,5*	53*	49*	45,5*	41*								
	NM 80/250CE	37	50	73,5	73	72	70,5	69*	67*	63*	59*	55,5*	51,5*								
	NM 80/250BE	45	60	84	83,5	82,5	81,5	80*	78*	74,5*	70,5*	67*	63*								
	NM 80/250AE	55	75	95	94,5	93,5	92,5	91,5*	90*	87,5*	84*	80,5*	76,5*								
	NM 100/200EE	18,5	25				30	29,5	29	28	27	26*	25*	23*	19*						
	NM 100/200DE	22	30				36	35,5	35	34	33	32*	31*	29*	24,5*	19*					
	NM 100/200CE	30	40				45	44,5	44	43,5	42,5	41,5*	40,5*	39*	34,5*	29*					
	NM 100/200BE	37	50				54	53,5	53	52,5	51,5	50,5*	49,5*	48*	44*	38,5*	32*				
	NM 100/200AE	45	60				61,5	61	60,5	60	59,5	58,5*	58*	56,5*	53*	48*	42*				
	NM 100/250BE	55	75				73,5	73	72,5	71,5	70	68,5*	67*	65*	61*	55,5*	48,5*				
	NM 100/250AE	75	100				91	90,5	90	89,5	88,5	88*	87*	85*	81*	75*	67*				

NM Standard construction.
B-NM Bronze construction.

P₂ Rated motor power output.
H Total head in m.

* Maximum suction lift 1-2 m.
◦ With 1 m suction head.

Tolerances according to ISO 9906, annex A.

Rated currents

P ₂		230V Δ / 400V Y 400V Δ / 690V Y			IA/IN
kW	HP	IN A	IN A	IN A	
0,55	0,75	3	1,7		4,3
0,75	1	4	2,3		5,2
1,1	1,5	5	2,9		5,3
1,5	2	7,5	4,3		5,8
2,2	3	9,15	5,3		6
3	4	11,5	6,6		9
4	5,5		9,6	5,5	9,3
5,5	7,5		12	7	8,3
7,5	10		16	9,2	8,8
9,2	12,5		18,5	10,7	8,3
11	15		21,5	12,4	8,4
15	20		27,5	15,9	8,8
18,5	25		34	19,6	9,7
22	30		42	24,2	9
30	40		54	31,2	9
37	50		68	39,5	8,5
45	60		85	49	8
55	75		105	60	7,2
75	100		140	81	6

P₂ Potenza nominale motore.
IA/IN Corrente di spunto / Corrente nominale.

Characteristic curves $n \approx 2900$ rpm

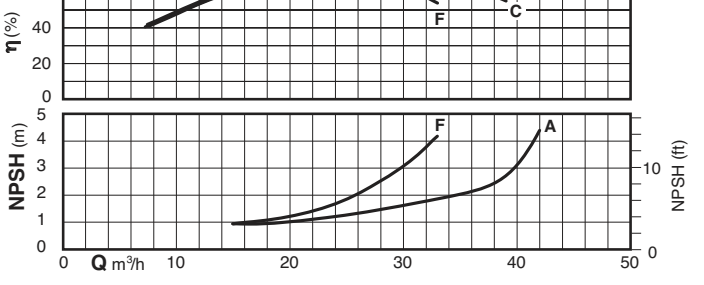
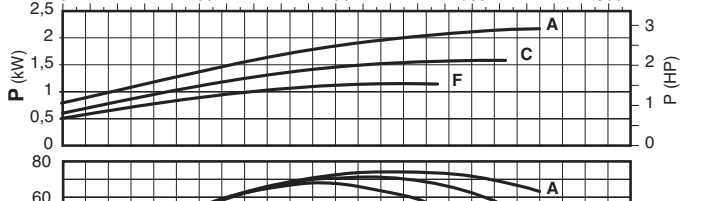
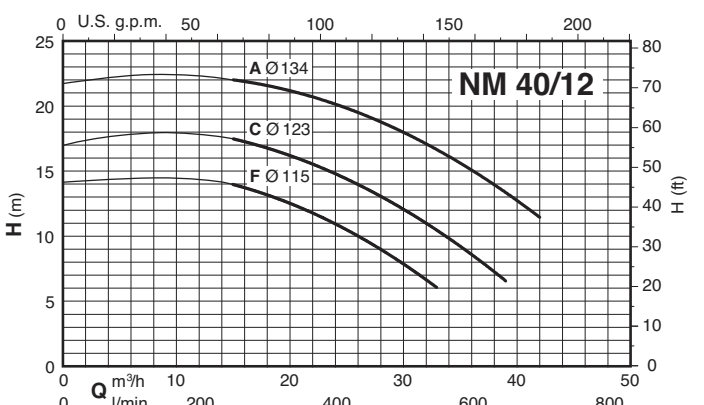
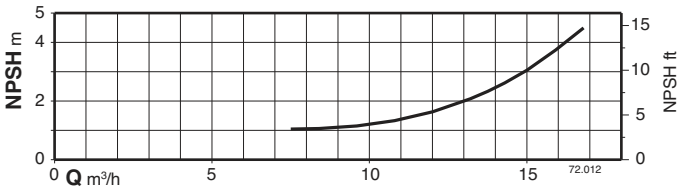
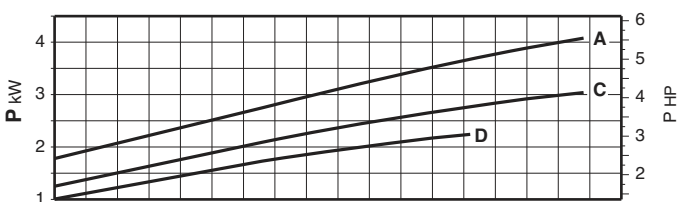
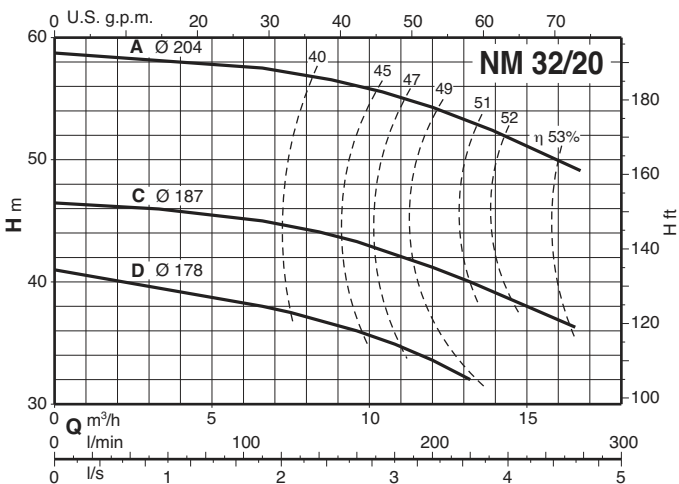
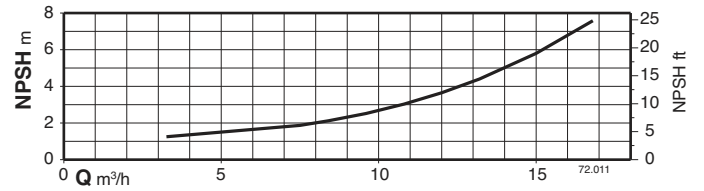
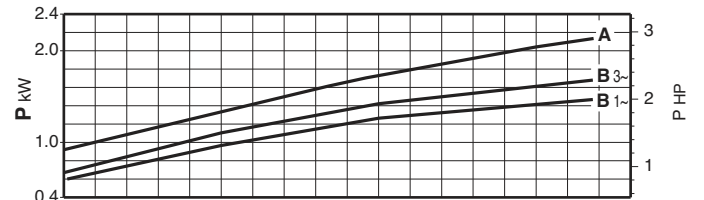
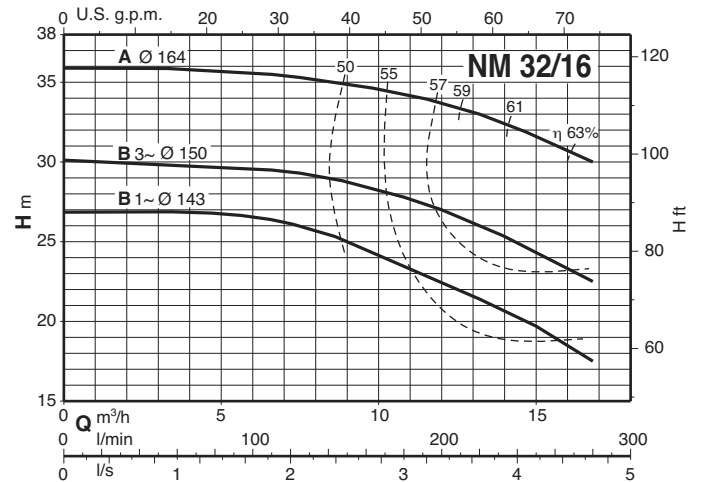
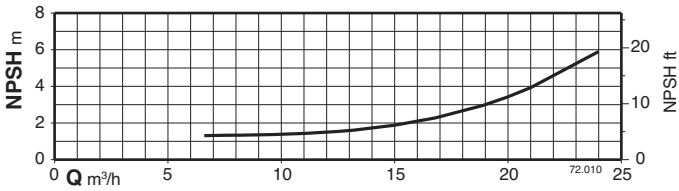
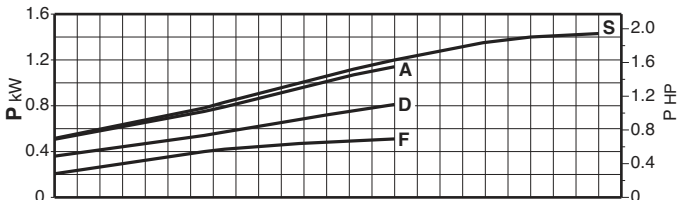
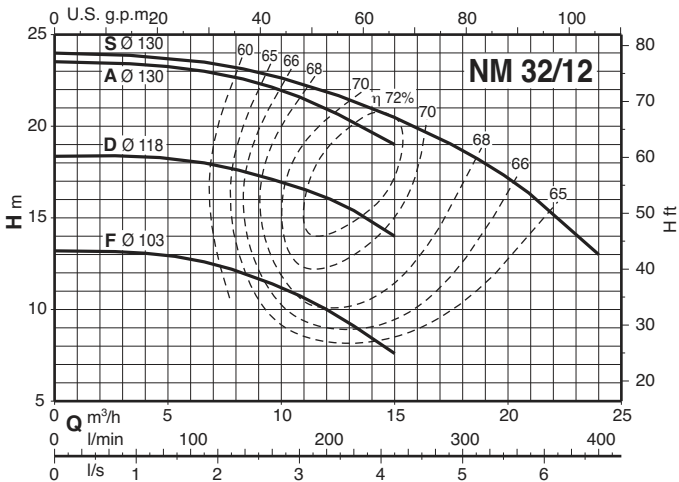

Characteristic curves $n \approx 2900$ rpm

2

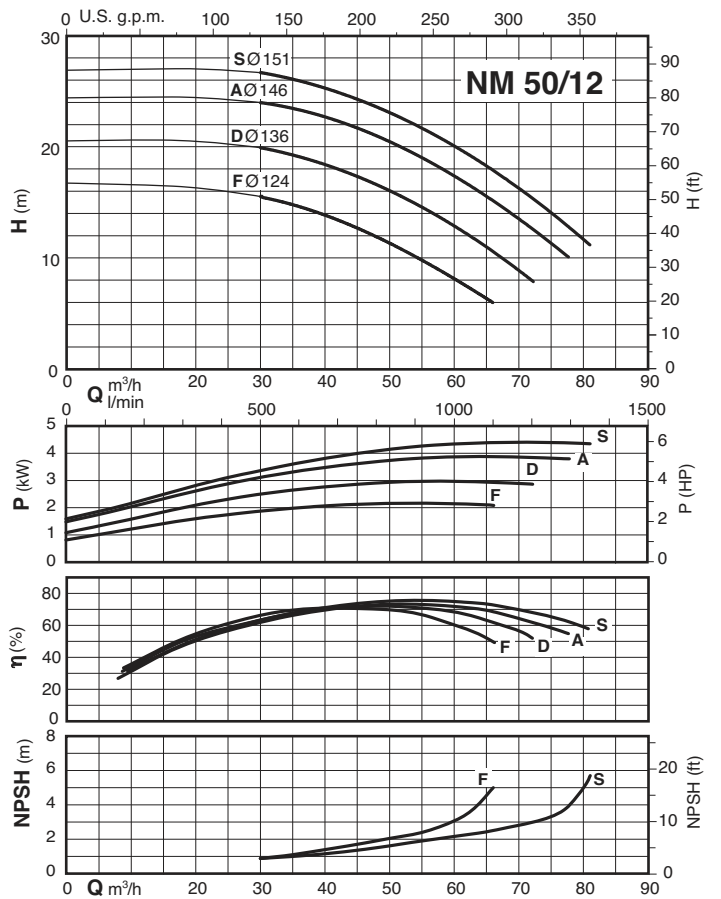
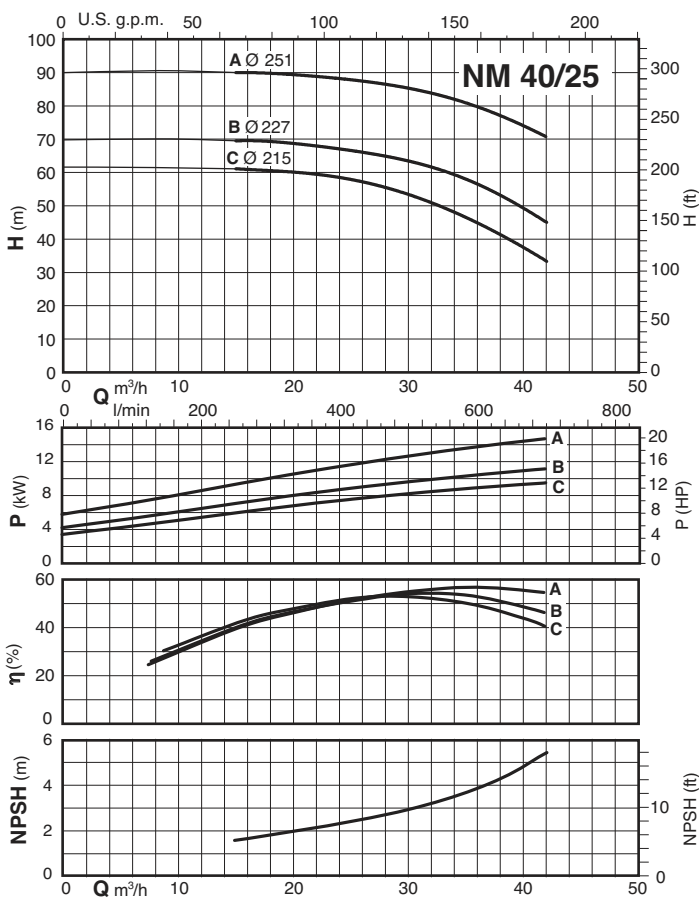
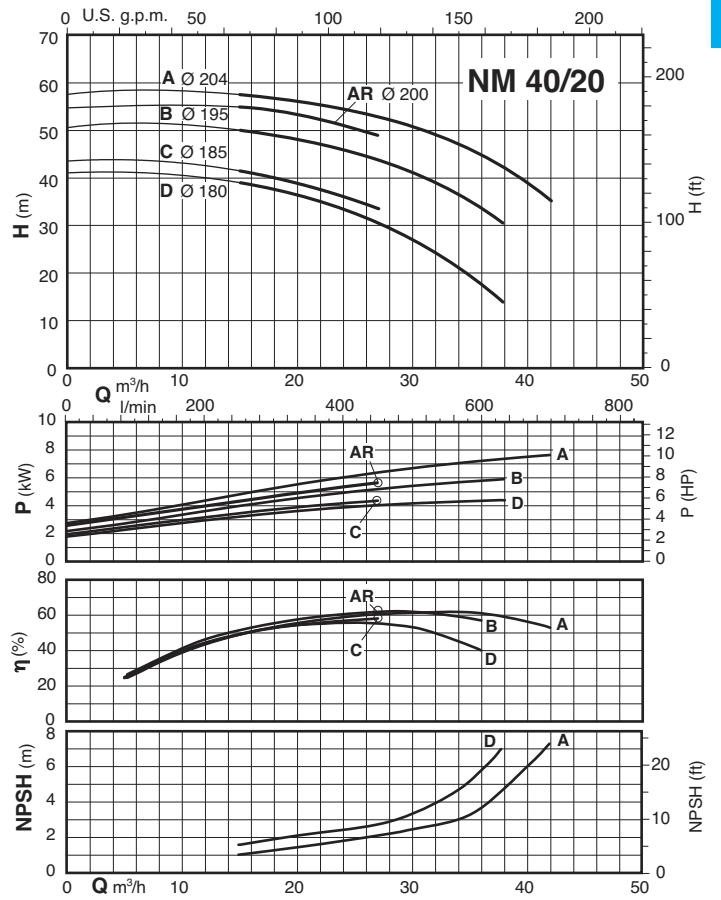
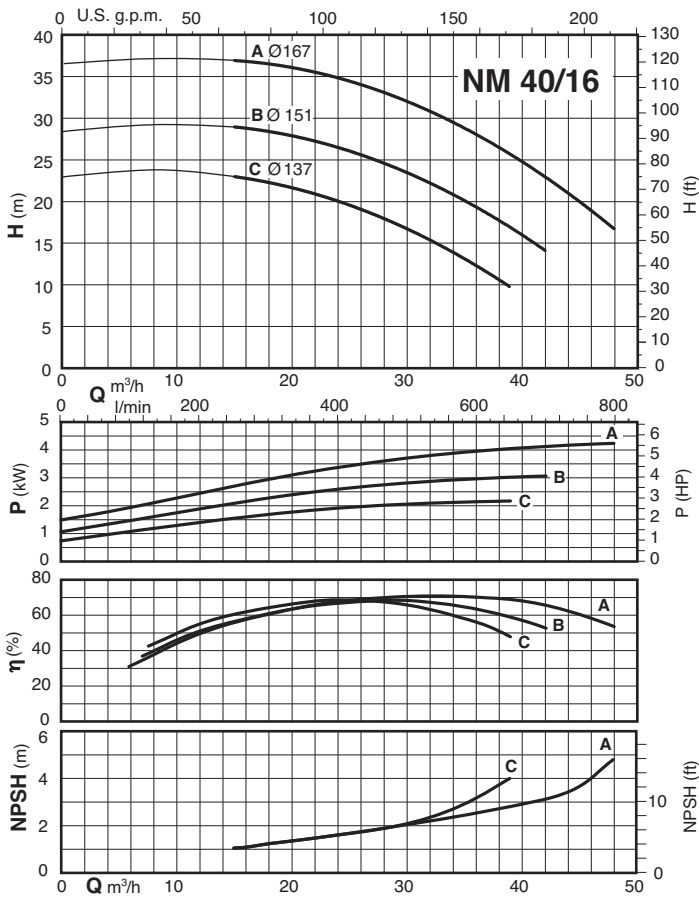

Characteristic curves $n \approx 2900$ rpm

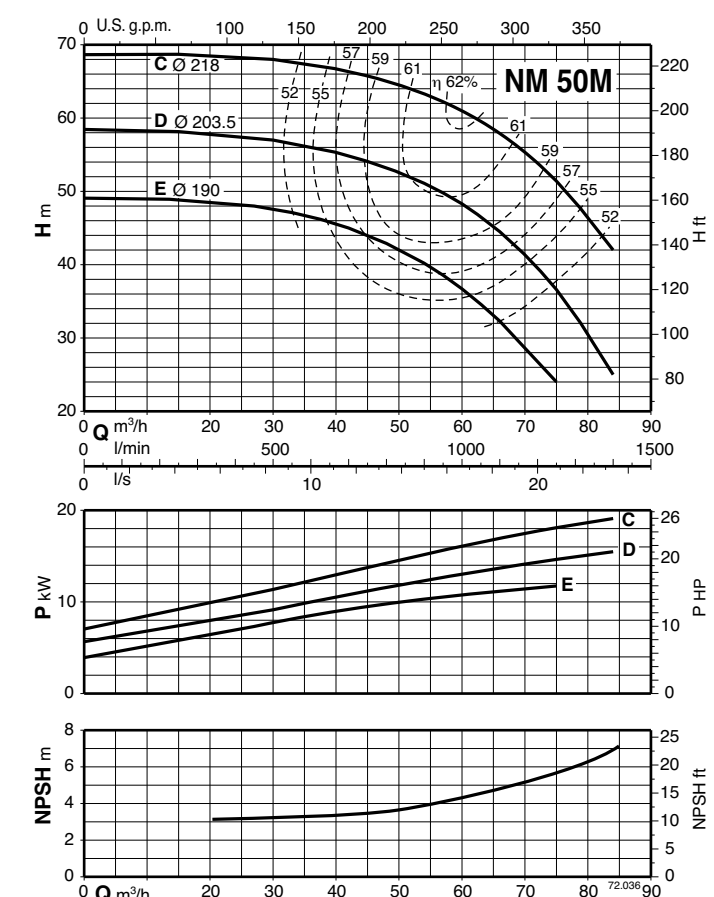
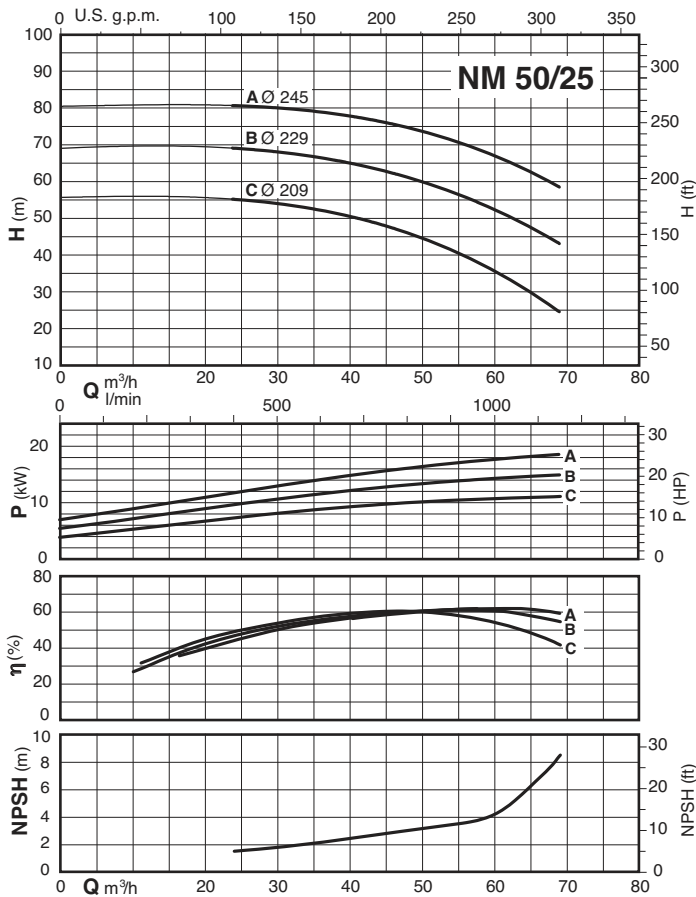
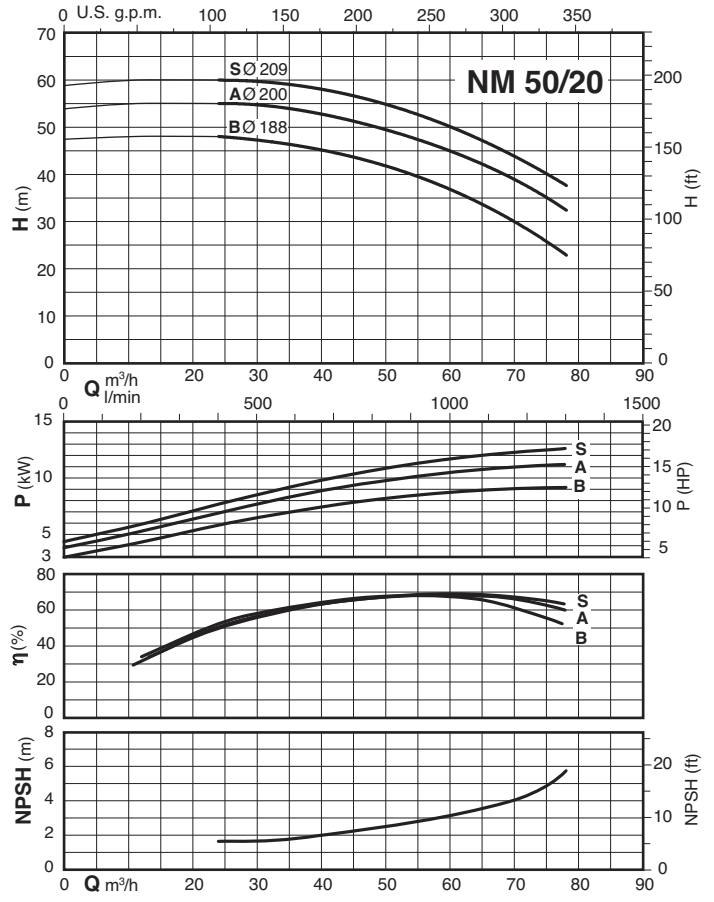
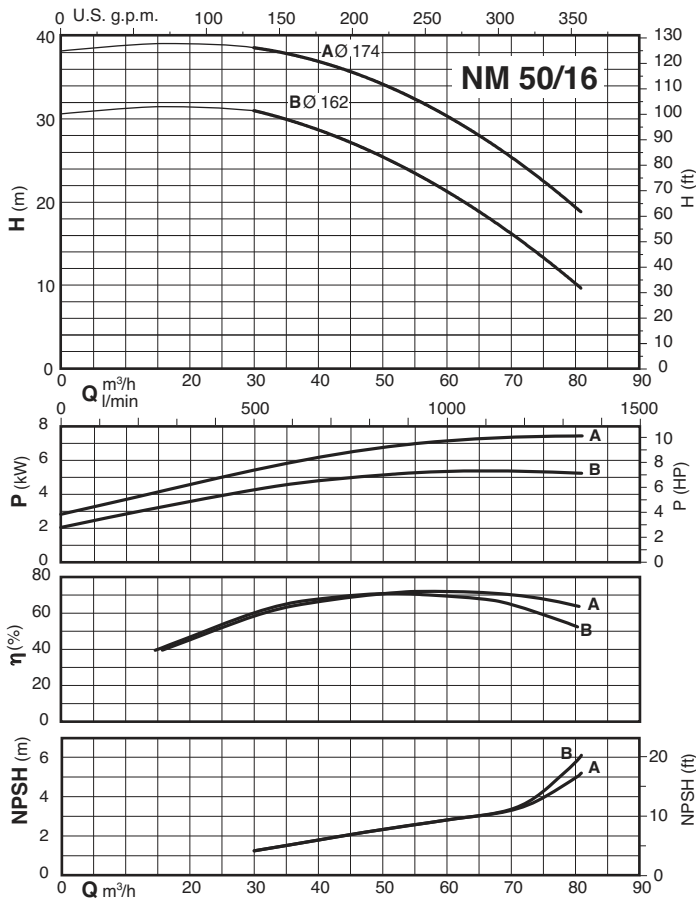

Characteristic curves $n \approx 2900$ rpm

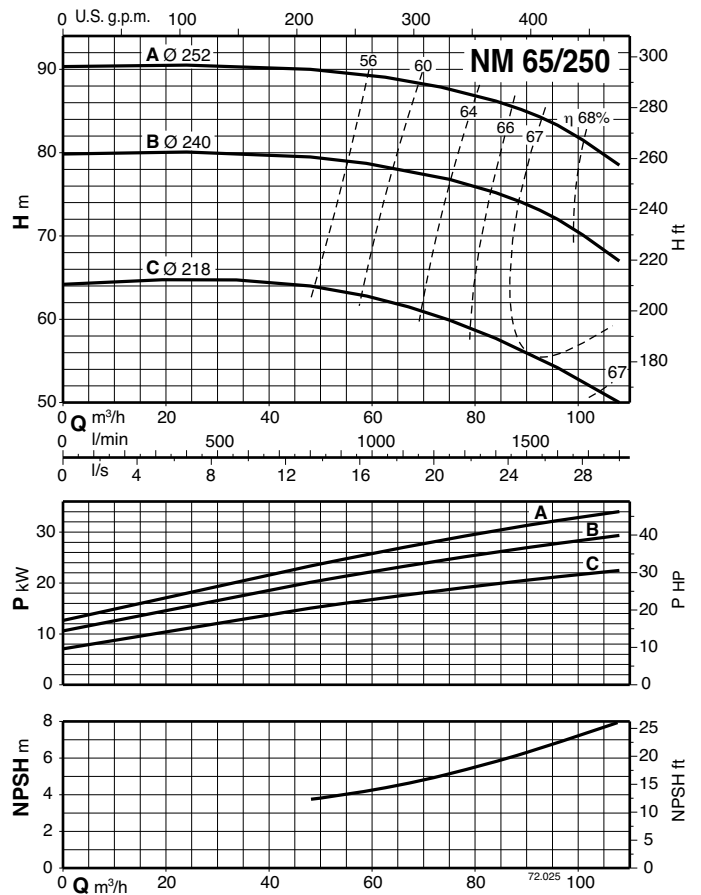
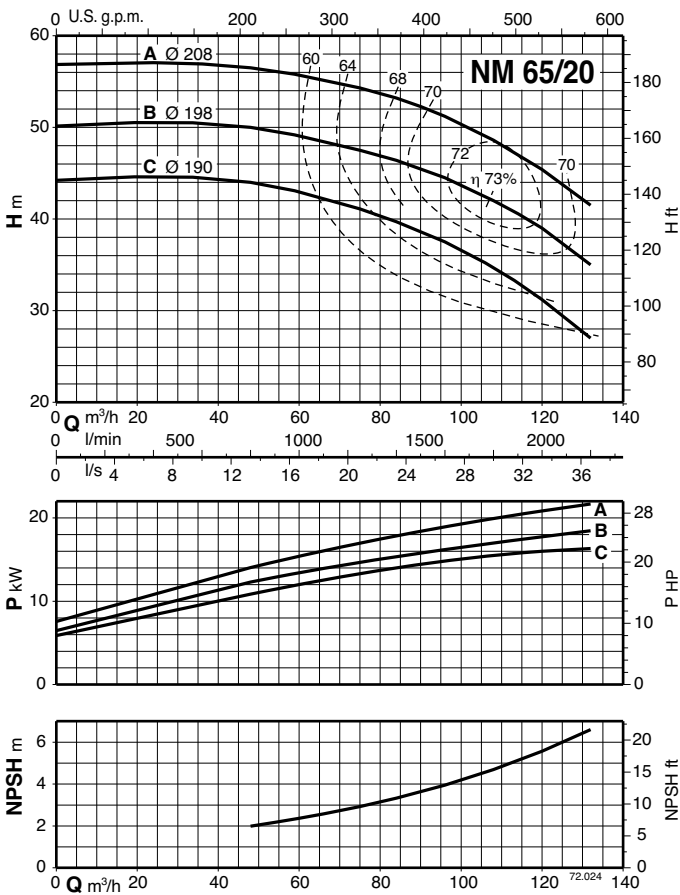
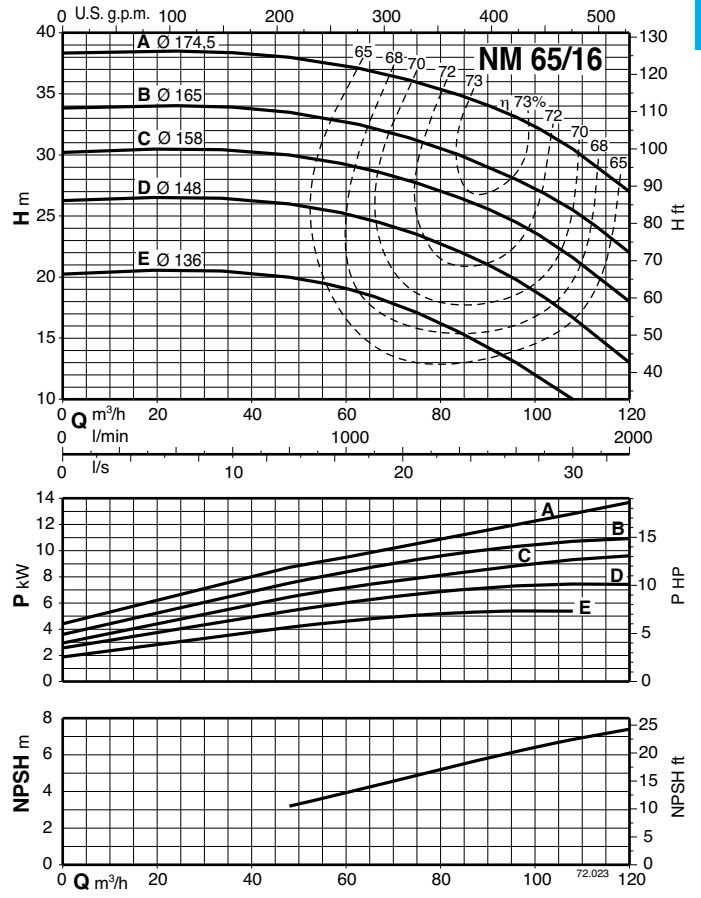
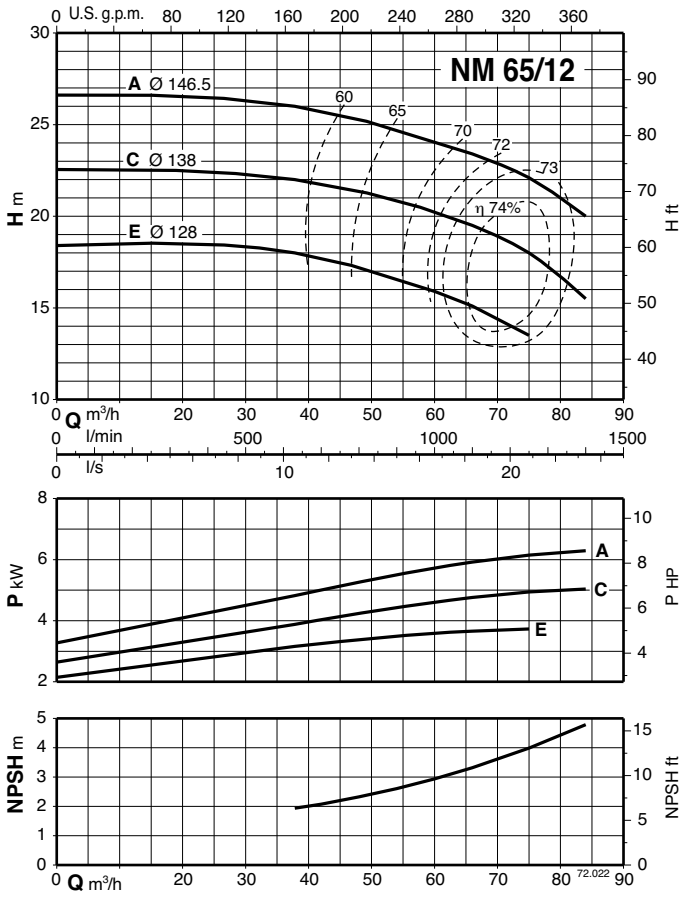

Characteristic curves $n \approx 2900$ rpm

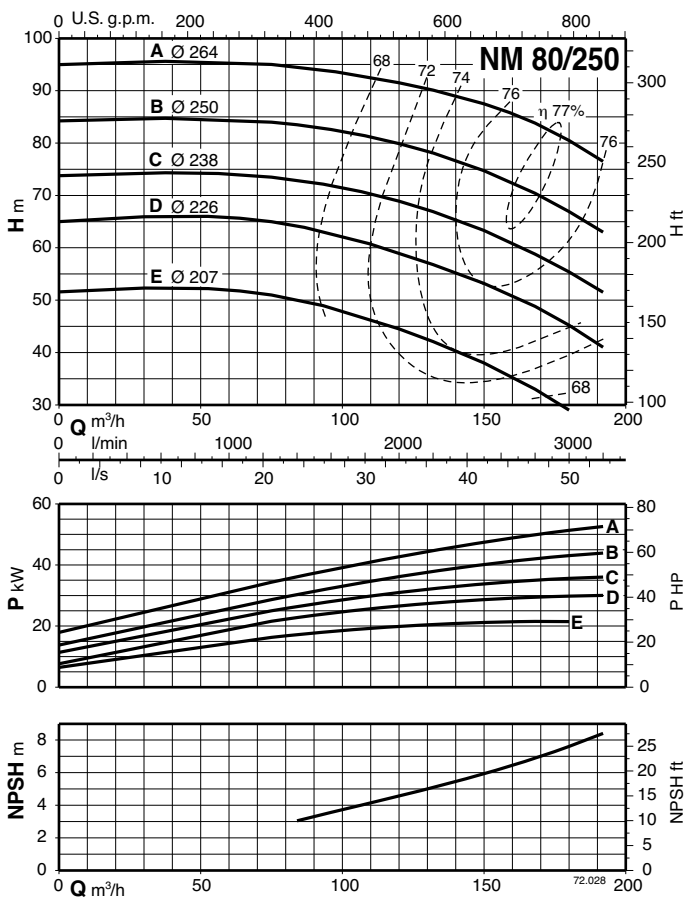
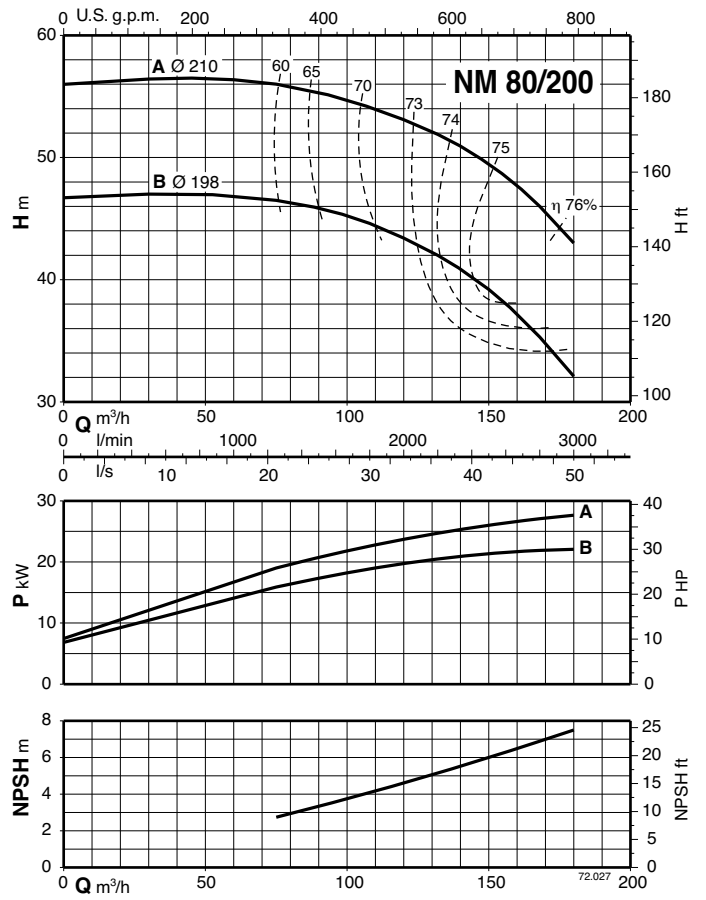
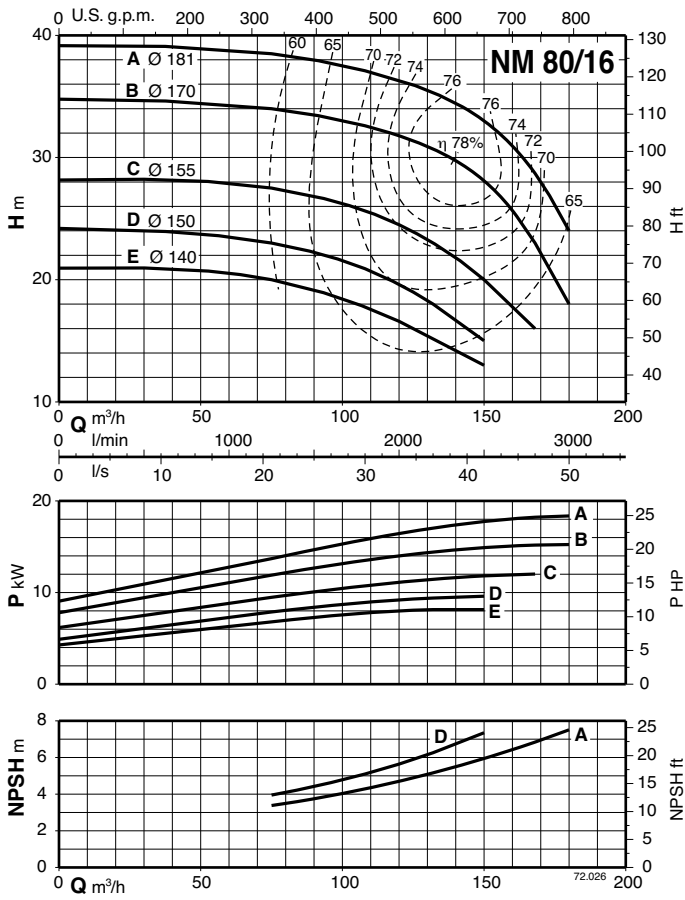

Characteristic curves $n \approx 2900$ rpm

2

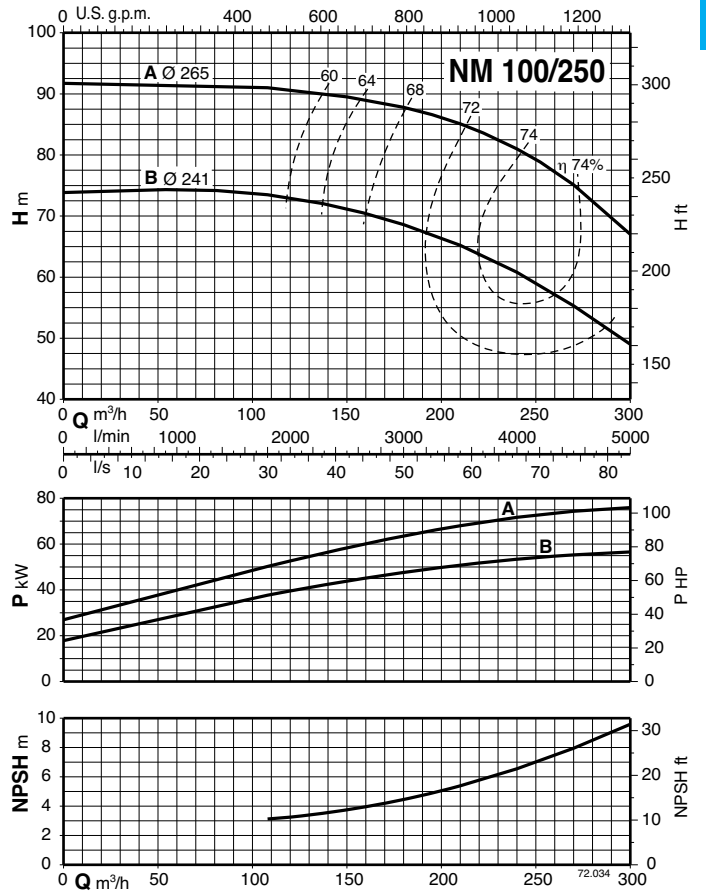
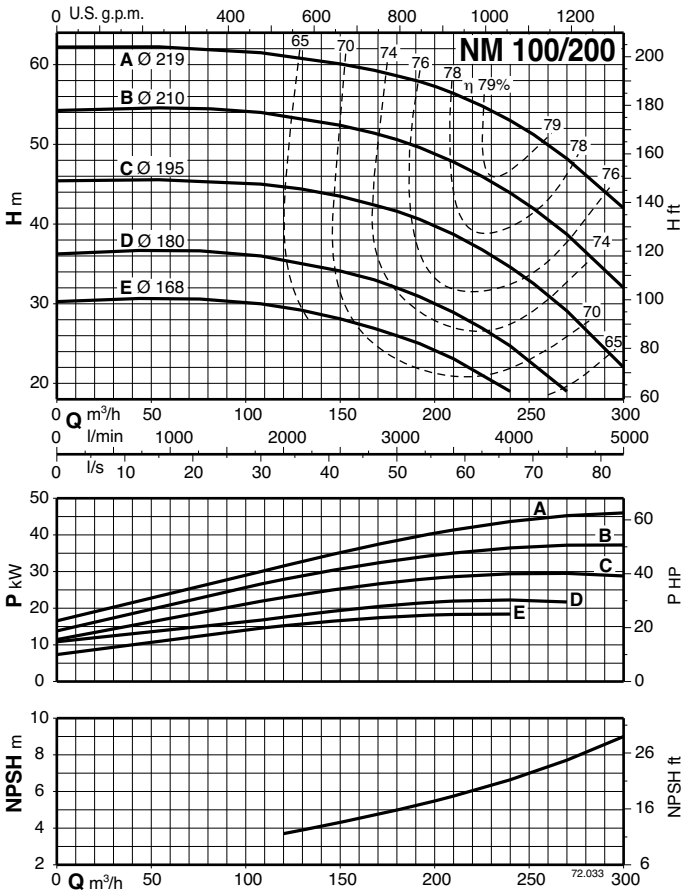

Dimensions and weights

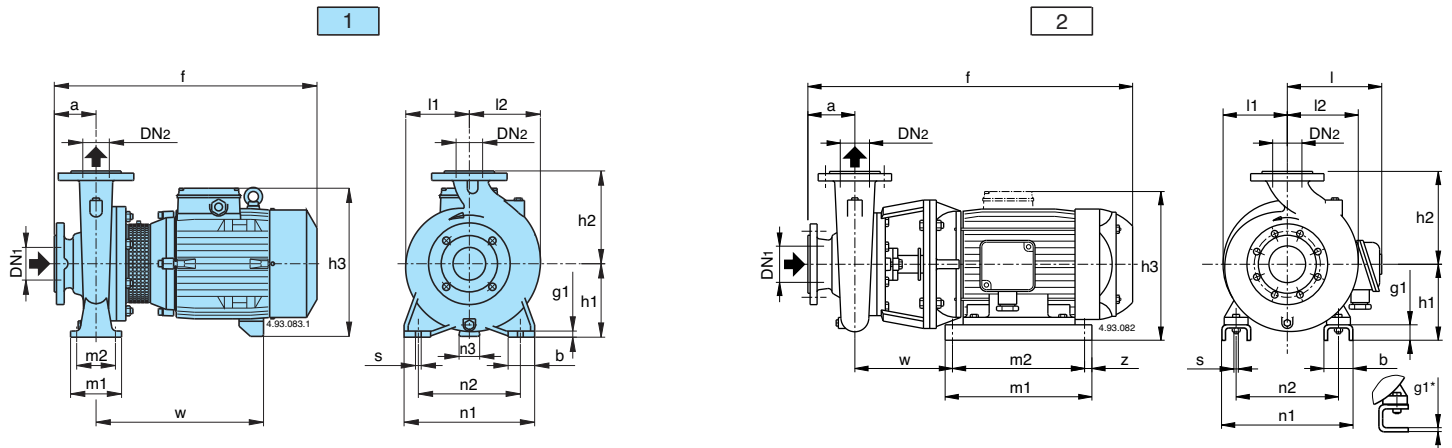

Picture	NM	mm																			kg										
		DN1	DN2	a	f	h1	h2	h3	m1	m2	n1	n2	n3	z	b	s	l	l1	l2	w	g1										
1	NM 32/12SE-AE-DE-FE	50	32	80	405	112	140	240	100	70	190	140	37	-	50	14	-	93	97	245	12	27-25-24-24									
	NM 32/16AE-BE	50	32	80	410	132	160	260	100	70	240	190	47	-	50	14	-	120	120	250	12	36-34									
	NM 32/20DE	50	32	80	410	160	180	288	100	70	240	190	62	-	50	14	-	140	140	250	12	39									
	NM 32/20CE				60								295							49											
	NM 32/20AE				60								295							52											
	NM 40/12A/A-C/A-F/A	65	40	80	410	112	140	240	100	70	210	160	37	-	50	14	-	100	113	250	12	31-29-27									
	NM 40/16C/A	65	40	80	410	132	160	260	100	70	240	190	47	-	50	14	-	119	119	250	12	36									
	NM 40/16B/A				45								295							45											
	NM 40/16A/A				45								295							49											
	NM 40/20CE-DE	65	40	100	495	160	180	288	100	70	265	212	60	-	50	14	-	140	140	295	12	55-55									
	NM 40/20AE-ARE-BE				525			320					49							72-65-65											
	NM 40/25B/A-C/A	65	40	100	640	180	225	365	125	95	320	250	50	-	65	14	-	175	175	410	15	116-110									
	NM 40/25A/A				690								50							133											
	NM 50/12F/A	65	50	100	430	132	160	260	100	70	240	190	47	-	50	14	-	121	137	250	12	38									
NM 50/12D/A	495				45								47																		
NM 50/12A/A-S/A	495				45								51-51																		
NM 50/16A/A-B/A	65	50	100	525	160	180	320	100	70	265	212	49	-	50	14	-	127	141	320	14	70-64										
NM 50/20A/A-B/A	65	50	100	640	160	200	345	100	70	265	212	40	-	50	14	-	140	153	410	15	106-100										
NM 50/20S/A				695															112												
NM 50/25C/A	65	50	100	645	180	225	365	125	95	320	250	50	-	65	14	-	175	175	415	15	126										
NM 50/25B/A				695															465		132										
NM 50/25A/A				720															465		147										
NM 50M/EE	65	50	100	700	192	225	377	298	258	262	216	-	20	69	12	-	175	175	239	6*	135										
NM 50M/DE				750															151												
NM 50M/CE				775															165												
NM 65/12EE	80	65	100	495	160	180	288	125	95	280	212	60	-	65	14	-	134	156	295	15	55										
NM 65/12AE-CE				525			320					73-67																			
NM 65/16DE-EE	80	65	100	525	160	200	320	125	95	280	212	49	-	65	14	-	150	172	410	15	75-70										
NM 65/16BE-CE				640			40					106-100																			
NM 65/16AE				690			40					121																			
NM 65/20CE	80	65	100	690	180	225	365	125	95	320	250	50	-	65	14	-	155	175	460	15	127										
NM 65/20BE				715															139												
NM 65/200AE	80	65	100	825	202	225	408	400	360	344	254	-	20	90	14	-	155	175	245	42	164										
NM 65/250BE-CE	80	65	100	825	202	250	408	400	360	344	254	-	20	90	14	-	175	190	245	42	195-174										
NM 65/250AE				945			245												425		408			318	25	90	18	290	263	45	299
NM 80/16EE	100	80	125	545	180	225	340	125	95	320	250	60	-	65	14	-	165	193	320	15	83										
NM 80/16CE-DE				670			50					113-108																			
NM 80/16BE				720			50					130																			
NM 80/16AE				745			50					144																			
NM 80/200AE-BE	100	80	125	850	202	250	408	400	360	344	254	-	20	90	14	-	170	194	245	42	194-173										
NM 80/250DE-EE	100	80	125	850	202	280	408	400	360	344	254	-	20	90	14	-	191	210	245	42	203-182										
NM 80/250AE-BE-CE				970			245												425		408			318	25	90	18	290	263	45	377-361-331
NM 100/200EE	125	100	125	800	192	280	377	400	298	258	262	216	-	20	69	12	-	180	212	239	6*	173									
NM 100/200CE-DE				850			20													90		14			245	42	195-174				
NM 100/200AE-BE				970			245													408		318			25	90	18	290	263	45	355-323
NM 100/250BE	125	100	140	980	245	280	-	475	425	408	318	-	25	90	18	290	205	233	263	45	386										
NM 100/250AE				1050															275		480			430	460	356	104	330	305	50	498

Flanges
EN 1092-2

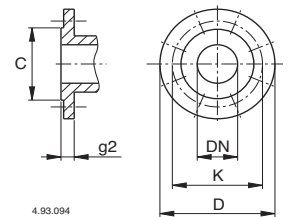

mm					
DN	C	K	D	Holes N° Ø	g2
32	76	100	140	4 19	18
40	84	110	150	4 19	18
50	99	125	165	4 19	20
65	118	145	185	4 19	20
80	132	160	200	8 19	22
100	156	180	220	8 19	24
125	184	210	250	8 19	24

Dimensions and weights

2

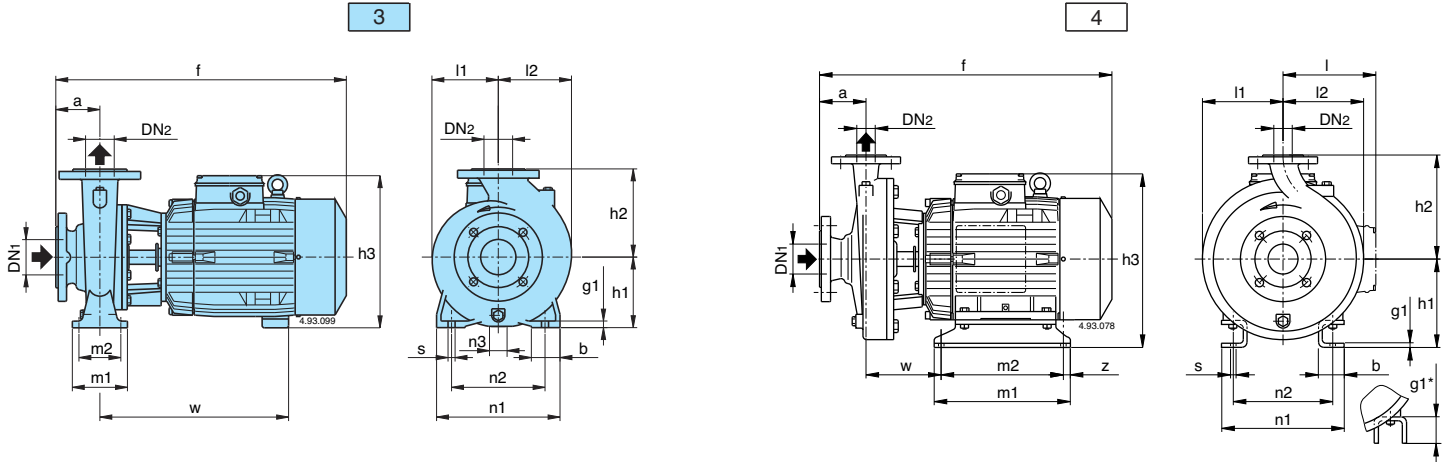

Picture	B- NM	mm																			kg	
		DN1	DN2	a	f	h1	h2	h3	m1	m2	n1	n2	n3	z	b	s	l	l1	l2	w	g1	B-NM
3	B-NM 32/125SE-AE B-NM 32/125DE-FE	50	32	80	450	112	140	240	100	70	190	140	37	-	50	14	-	93	97	290	12	33-32 31-29
	B-NM 32/160BE B-NM 32/160AE	50	32	80	455 475	132	160	260	100	70	240	190	47	-	50	14	-	120	120	295 315	12	44 45
	B-NM 32/200DE B-NM 32/200CE B-NM 32/200AE	50	32	80	475 530 530	160	180	288	100	70	240	190	60 60	-	50	14	-	140	140	315 350 350	12	49 57 61
	B-NM 40/125F/A B-NM 40/125A/A-C/A	65	40	80	455 475	112	140	240	100	70	210	160	37	-	50	14	-	100	113	295 315	12	33 37-35
	B-NM 40/160C/A B-NM 40/160B/A B-NM 40/160A/A	65	40	80	475 530 530	132	160	260	100	70	240	190	47 45 45	-	50	14	-	119	119	315 350 350	12	45 53 57
	B-NM 40/200CE-DE B-NM 40/200AE-BE	65	40	100	550 580	160	180	288 320	100	70	265	212	60 49	-	50	14	-	140	140	350 375	12	63-62 80-74
	B-NM 4025/B/A-C/A B-NM 4025/A/A	65	40	100	635 685	192	225	377	298	258	262	216	-	20	69	12	-	175	175	174	6	130-124 147
3	B-NM 50/125F/A B-NM 50/125D/A B-NM 50/125A/A-S/A	65	50	100	495 550 550	132	160	260	100	70	240	190	47 45 45	-	50	14	-	121	137	315 350 350	12	49 58 63-63
	B-NM 50/160A/A-B/A	65	50	100	580	160	180	320	100	70	265	212	49	-	50	14	-	127	141	375	14	80-74
	B-NM 50/200S/A-A/A-B/A	65	50	100	695	192	200	377	298	258	262	216	-	20	69	12	-	140	153	234	6	128-121
4	B-NM 5025/C/A B-NM 5025/B/A B-NM 5025/A/A	65	50	100	635 685 710	192	225	377	298	258	262	216	-	20	69	12	-	175	175	174	6	135 144 155
	B-NM 5025/65EE B-NM 5025/65DE B-NM 5025/65CE	65	50	100	635 685 710	192	225	377	298	258	262	216	-	20	69	12	-	175	175	174	6	135 144 155
	B-NM 65/125AE-CE B-NM 65/160DE-EE B-NM 65/160CE	80	65	100	580 575 660	160	200	320 345	125	95	280	212	49 40	-	65	14	-	134	156	375 430	15	93-72 83-78 108
4	B-NM 65/160BE B-NM 65/160AE	80	65	100	695 745	192	200	377	298	258	262	216	-	20	69	12	-	150	172	234	6	149 166
	B-NM 65/200CE B-NM 65/200BE B-NM 65/200AE	80	65	100	750 775 825	192 225	225	377 408	298 400	258 360	262 344	216 254	-	20	69 90	12 14	-	155	175	239 245	6 42*	157 177 179
	B-NM 65/250BE-CE NM 65/250BE B-NM 65/250AE	80	65	100	825 840 945	202 225	250	408 - 475	400 387 425	360 347 425	344 369 408	254 279 318	-	20	90 25	14 18	-	175	190	245 258 263	42* 42* 45*	210-189 350
	B-NM 80/160EE B-NM 80/160DE	100	80	125	605 685	180	225	340 365	125	95	320	250	60 50	-	65	14	-	165	193	375 430	15	108 116
	B-NM 80/160CE B-NM 80/160BE B-NM 80/160AE	100	80	125	725 775 800	192	225	377	298	258	262	216	-	20	69	12	-	165	193	239	6	155 163 166

Flanges EN 1092-2

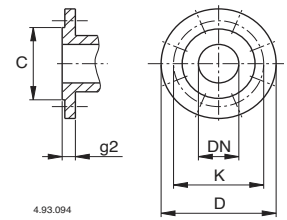

mm					
DN	C	K	D	Holes N° Ø	g2
32	76	100	140	4 19	18
40	84	110	150	4 19	18
50	99	125	165	4 19	20
65	118	145	185	4 19	20
80	132	160	200	8 19	22
100	156	180	220	8 19	24
125	184	210	250	8 19	24