



### Construction

Close-coupled centrifugal pumps with open impeller.  
Free-flow impeller (vortex or recessed impeller) for type C 16/1E.

### Applications

For moderately dirty liquids or emulsions.  
For industry and agriculture.

### Operating conditions

Liquid temperature from -10 °C to +90 °C.  
Ambient temperature up to 40 °C.  
Total suction lift up to 8 m.  
Maximum permissible working pressure: 6 bar.  
Maximum size of solids: 4 mm.  
Continuous duty.

### Motor

2-pole induction motor, 50 Hz (n = 2900 rpm).

**C:** three-phase 230/400 V ± 10%.

**CM:** single-phase 230 V ± 10%, with thermal protector.

Capacitor inside the terminal box.

Insulation class F.

Protection IP 54.

Constructed in accordance with: IEC 60034.

### Special features on request

- Other voltages.
- Frequency 60 Hz (as per 60 Hz data sheet).
- Protection IP 55.
- Special mechanical seal
- Higher or lower liquid or ambient temperatures.

### Materials

Component	C	B-C
Pump casing	Cast iron GJL 200 EN 1561	Bronze G-Cu Sn 10 EN 1982
Lantern bracket	Cast iron GJL 200 EN 1561	Bronze G-Cu Sn 10 EN 1982
Impeller	Brass P- Cu Zn 40 Pb 2 UNI 5705	
Shaft	Chrome steel 1.4104 EN 10088 (AISI 430)	Cr-Ni-Mo steel 1.4401 EN 10088 (AISI 316)
	Chrome-nickel steel 1.4305 EN 10088 (AISI 303) for C 41	
Mechanical seal	Carbon - Ceramic - NBR	

### Coverage chart n ≈ 2900 rpm

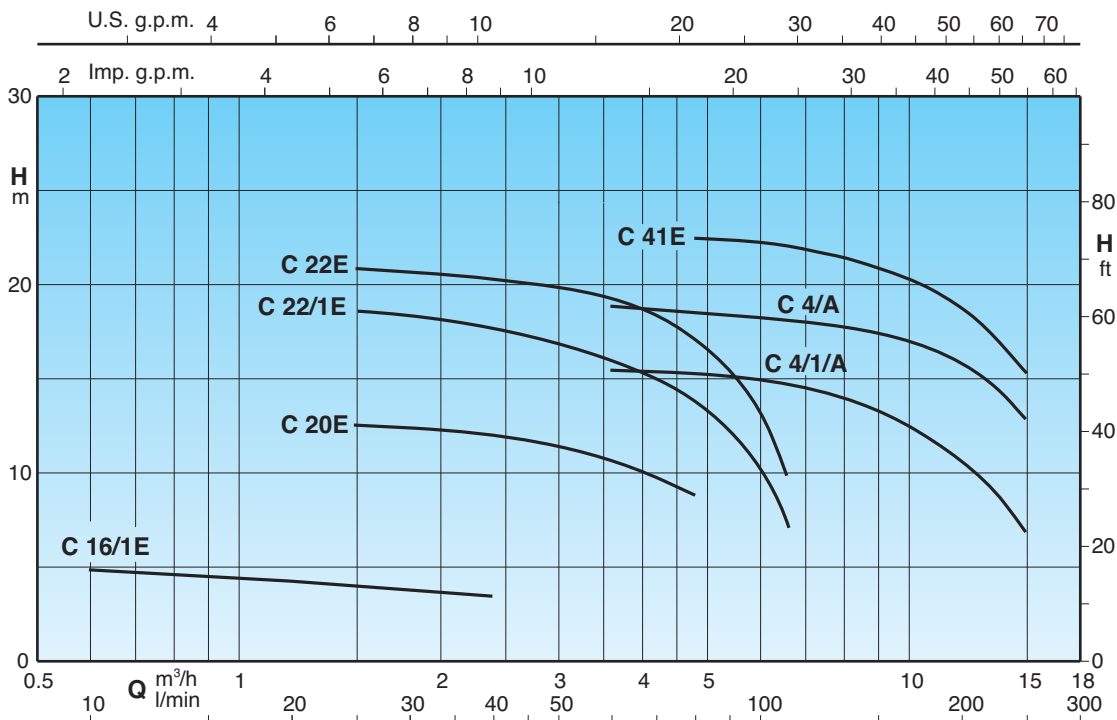



**Performance  $n \approx 2900$  rpm**

3 ~	230V 400V		1 ~	230V		P <sub>1</sub>		P <sub>2</sub>		Q m <sup>3</sup> /h l/min																
	A	A		A	kW	kW	HP	0,6	0,9		1,2	1,5	1,8	2,4	3	3,6	4,8	6	6,6	8,4	9,6	10,8	12	13,2	15	
<b>C 16/1E</b> B-C 16/1E	1,7	1	<b>CM 16/1E</b> B-CM 16/1E	1,2	0,16	0,15	0,2	<b>H</b> m	10	15	20	25	30	40	50	60	80	100	110	140	160	180	200	220	250	
<b>C 20E</b> B-C 20/A	1,9	1,1	<b>CM 20E</b> B-CM 20/A	2,5	0,4	0,37	0,5		5	4,7	4,4	4,2	4	3,6												
<b>C 22/1E</b> B-C 22/1/A	2,4	1,4	<b>CM 22/1E</b> B-CM 22/1/A	3	0,8	0,45	0,6					12,3	12,2	12	11,5	10,8	9									
<b>C 22E</b> B-C 22/A	3	1,7	<b>CM 22E</b> B-CM 22/A	3,5	0,9	0,55	0,75					18	18	17,5	17	16	14	10	7,5							
<b>C 4/1/A</b>	3	1,7	<b>CM 4/1/A</b>	4,5	0,91	0,55	0,75					21	21	20,5	20	19,5	17,5	13	10							
<b>C 4/A</b> B-C 4/1/E	3,7	2,2	<b>CM 4/A</b> B-CM 4/1/E	5,7	1,2	0,75	1									15,6	15,4	15,2	15	14	13,1	12	10,8	9,5	7	
<b>C 41E</b> B-C 41E	5	2,9	<b>CM 41E</b> B-CM 41E	7,4	1,6	1,1	1,5											19	18,8	18,5	18,3	17,7	17,4	16,8	16	15
																	22,4	22,3	22,2	21,5	21	20,5	19,5	18	15,5	

P<sub>1</sub> Maximum power input. P<sub>2</sub> Rated motor power output. B-C, B-CM = Bronze construction. H Total head in m.  $\rho$  = Density 1000 kg/m<sup>3</sup>.  $\nu$  = Kinematic viscosity max 20 mm<sup>2</sup>/sec. Tolerances according to ISO 9906, annex A.

**Dimensions and weights**

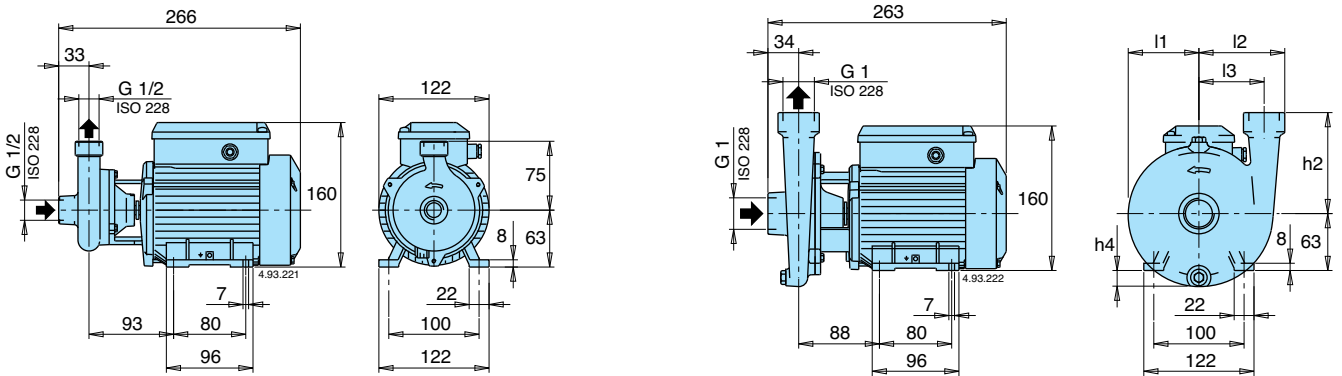

TYPE	kg
<b>C 16/1E</b>	5,2
<b>CM 16/1E</b>	5,2

TYPE	kg
<b>B-C 16/1E</b>	5,6
<b>B-CM 16/1E</b>	5,6

TYPE	mm					kg	
	h2	h4	l1	l2	l3	C	CM
<b>C 20E</b>	90	5	67	82	60	6,8	6,8
<b>C 22/1E - C 22E</b>	110	17	77	94	71	8 - 8,3	8 - 8,3

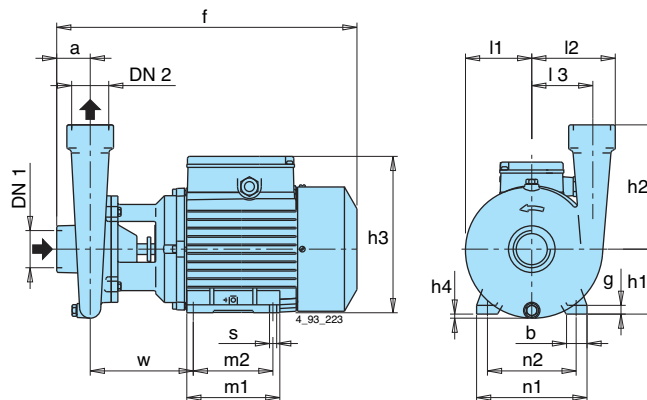

TYPE	DN <sub>1</sub>	DN <sub>2</sub>	mm																	kg				
			ISO 228	a	f	h1	h2	h3	h4	m1	m2	n1	n2	b	s	l1	l2	l3	w	g	C	CM	B-C	B-CM
- <b>B-C 20/A</b>	G 1	G 1	35	303	71	90	182	-	106	90	134	112	22	7	70	84	60	105	10	-	-	9,1	9,1	
- <b>B-C 22/1/A</b> - <b>B-C 22/A</b>	G 1	G 1	35	303	71	110	182	9	106	90	134	112	22	7	81	93	71	106	10	-	-	9,3 9,6	10,3 10,6	
<b>C 4/1/A</b> - <b>C 4/A</b>	-	G 1 1/2	G 1 1/2	43	304	71	160	182	18	106	90	134	112	22	7	85	108	78	100	10	10,8 11,8	11,8 12,8	-	-
- <b>B-C 41/1E</b> <b>C 41E</b> - <b>B-C 41E</b>	G 1 1/2	G 1 1/2	43	380	80	160	208	9	125	100	155	125	30	9,5	85	108	78	132	10	-	-	16,3 18,5	17,9 20,1	



**Characteristic curves  $n \approx 2900$  rpm**

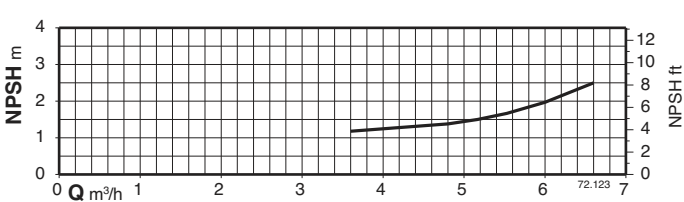
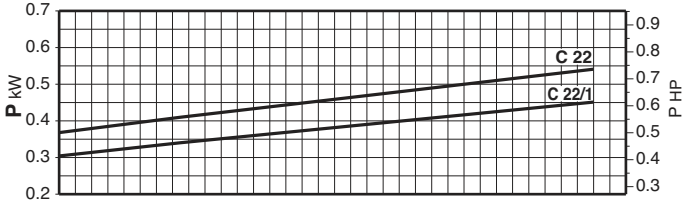
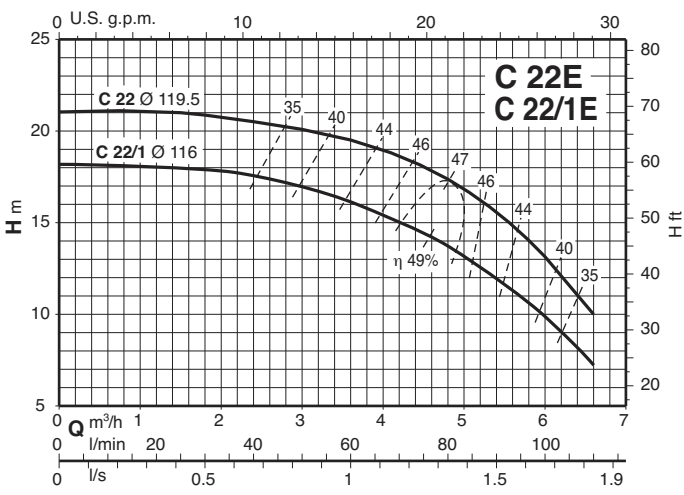
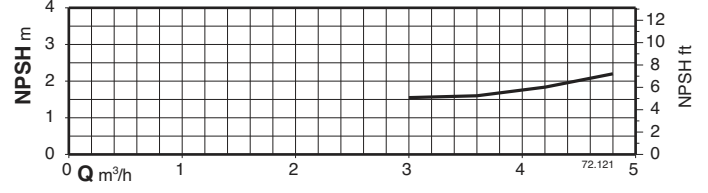
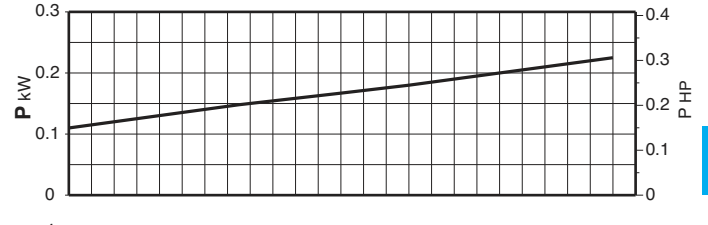
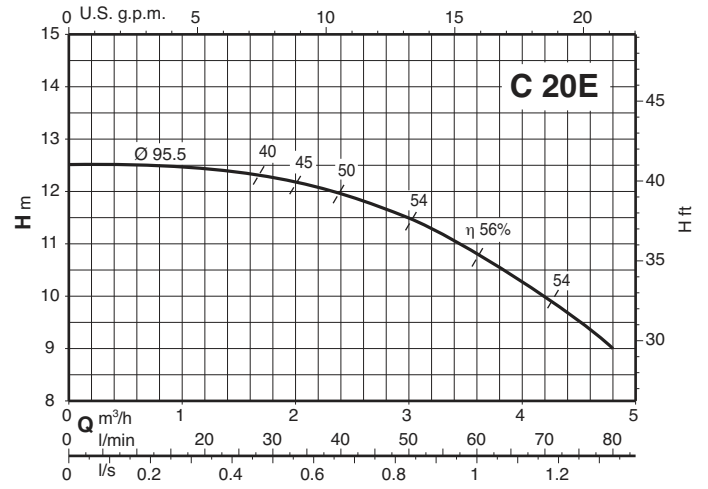
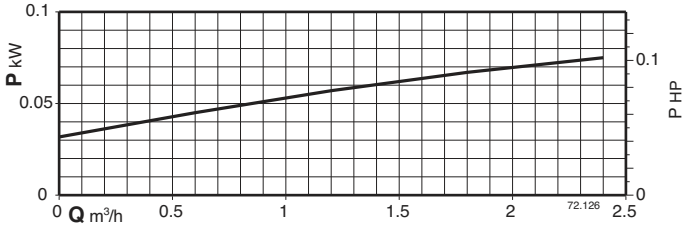
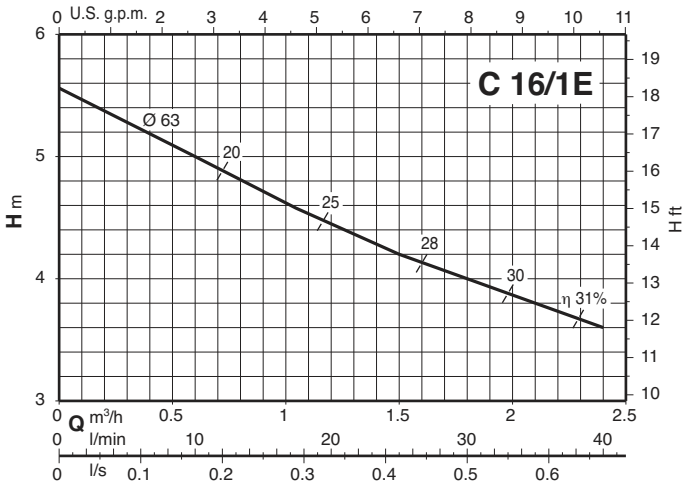



**Characteristic curves  $n \approx 2900$  rpm**

